

Drill: Frequency-Intro Set:

Set #1 Count: 0

2-333333

10

5

0

5

10

12-333333

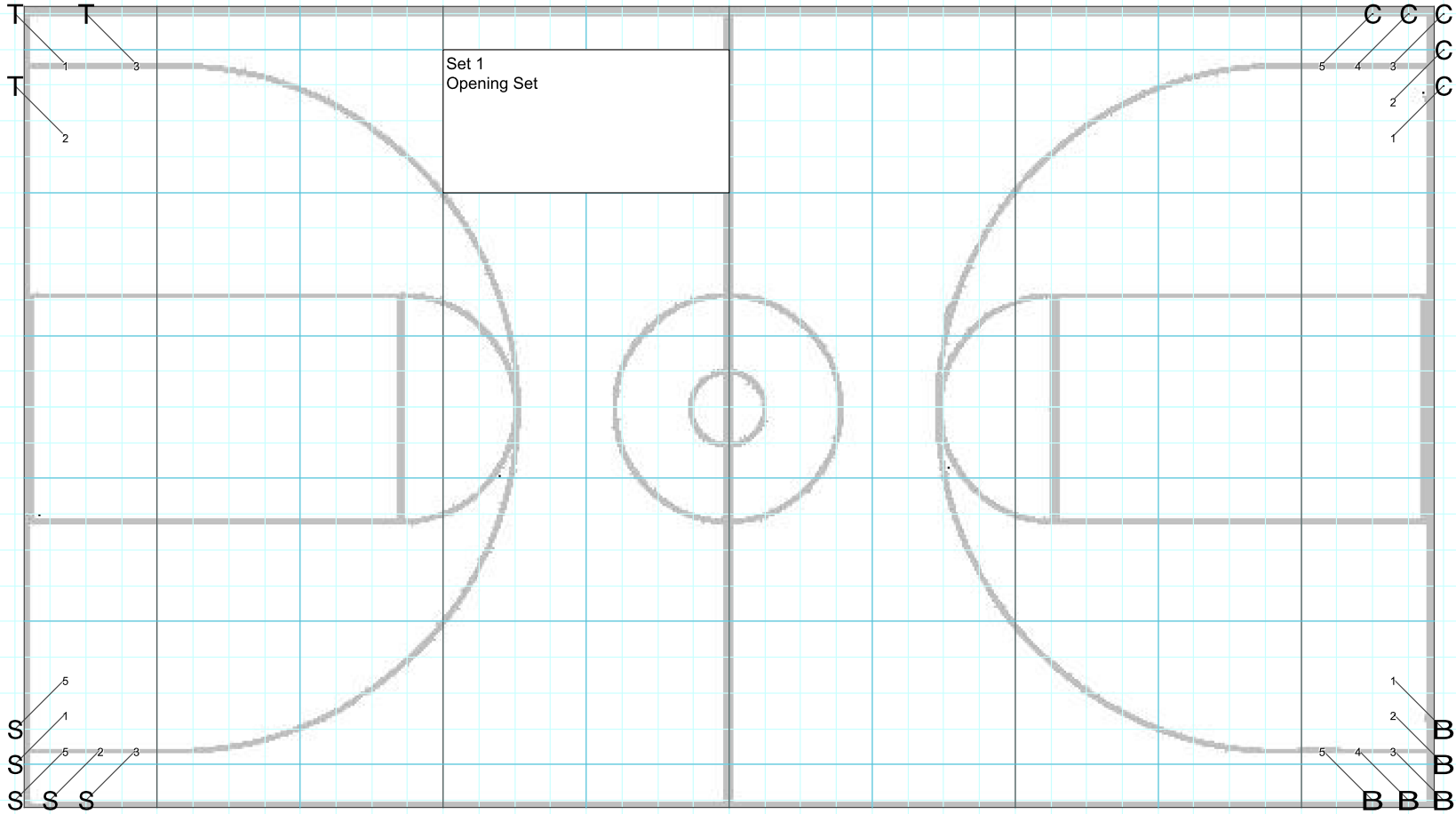

2-333333

10

5

0

5

10

12-333333

Director Viewpoint

2-333333

10

5

0

5

10

12-333333

Set 2
 Counts-32
 Snare 1 Move 32 Counts
 Snare 2-3 Move on 9 for 24 counts
 Snare 4-5 Move on 17 for 16 Counts
 All others move on 17 for 16 counts

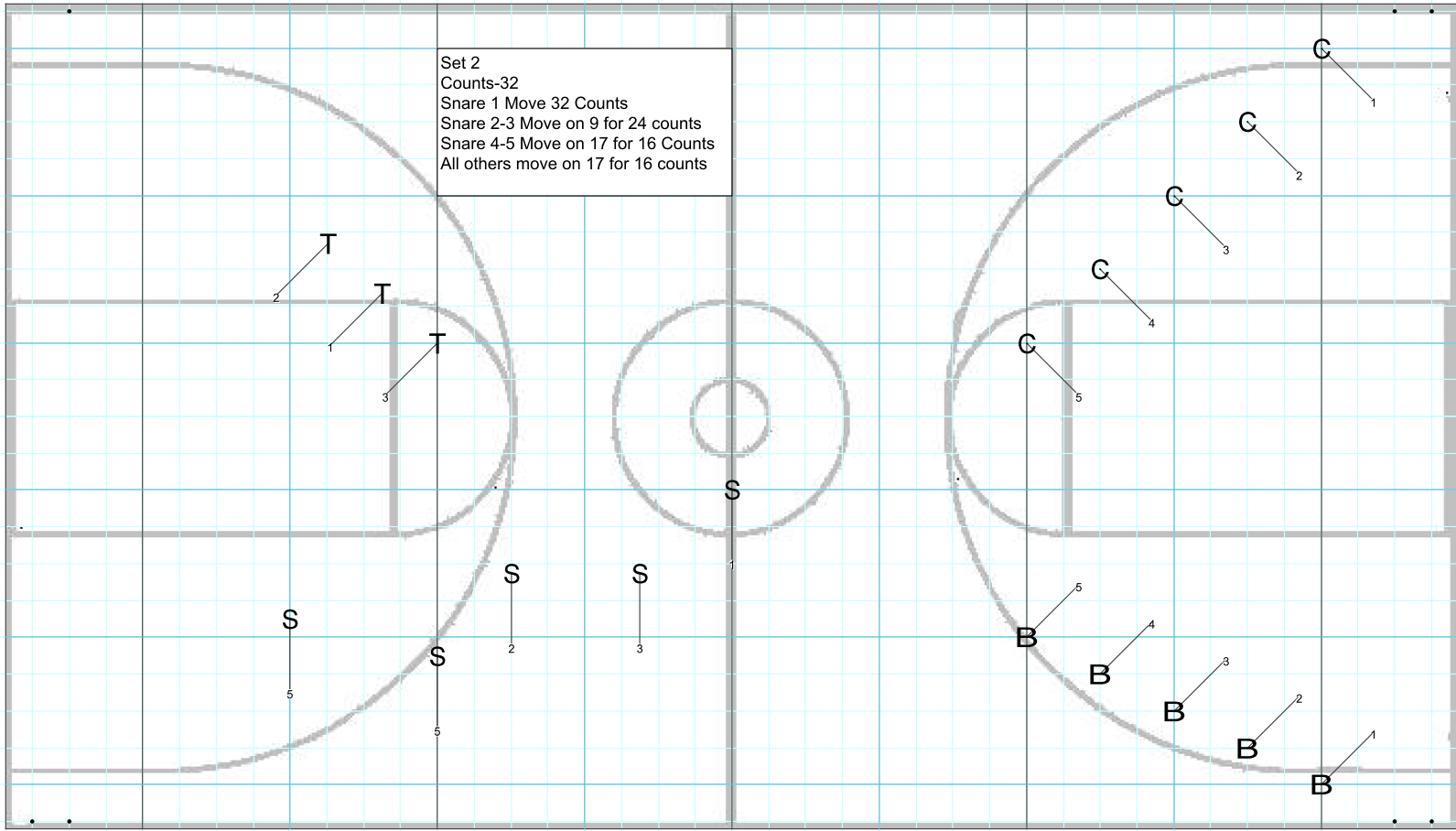

2-333333

10

5

0

5

10

12-333333

Director Viewpoint

2-333333

10

5

0

5

10

12-333333

Set 2-A
Counts-8
Snares 2-3 halt after 8 counts
Snares 4-5 keep moving to set 3

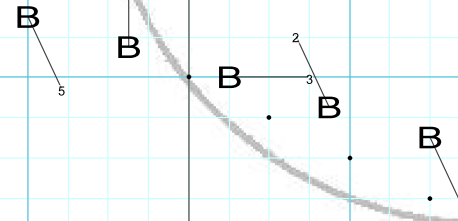
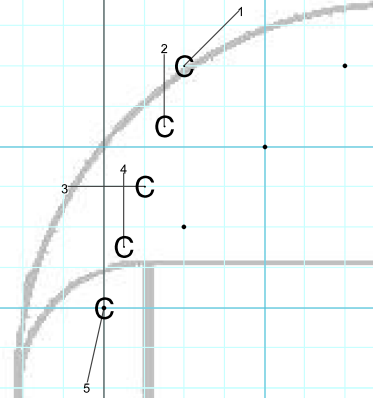
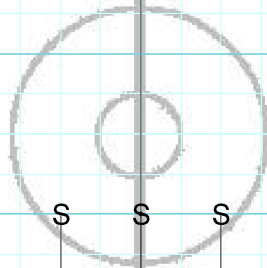
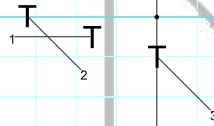

2-333333

10

5

0

5

10

12-333333

Director Viewpoint

2-333333

10

5

0

5

10

12-333333

Set-2B
Counts-8
Snare 4-5 Settle into Snareline
All others keep moving to set 3

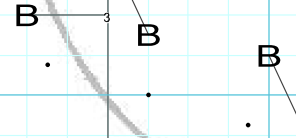
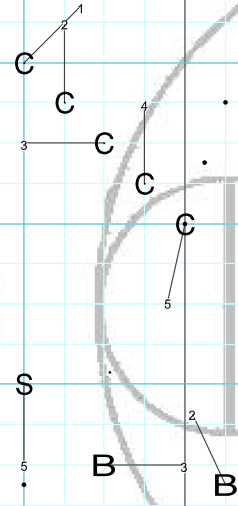
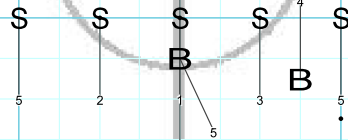
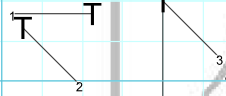

2-333333

10

5

0

5

10

12-333333

Director Viewpoint

2-333333

10

5

0

5

10

12-333333

Set-3
 Counts-32
 All Performers Move 32
 Bases Path is behind snareline on Side B.

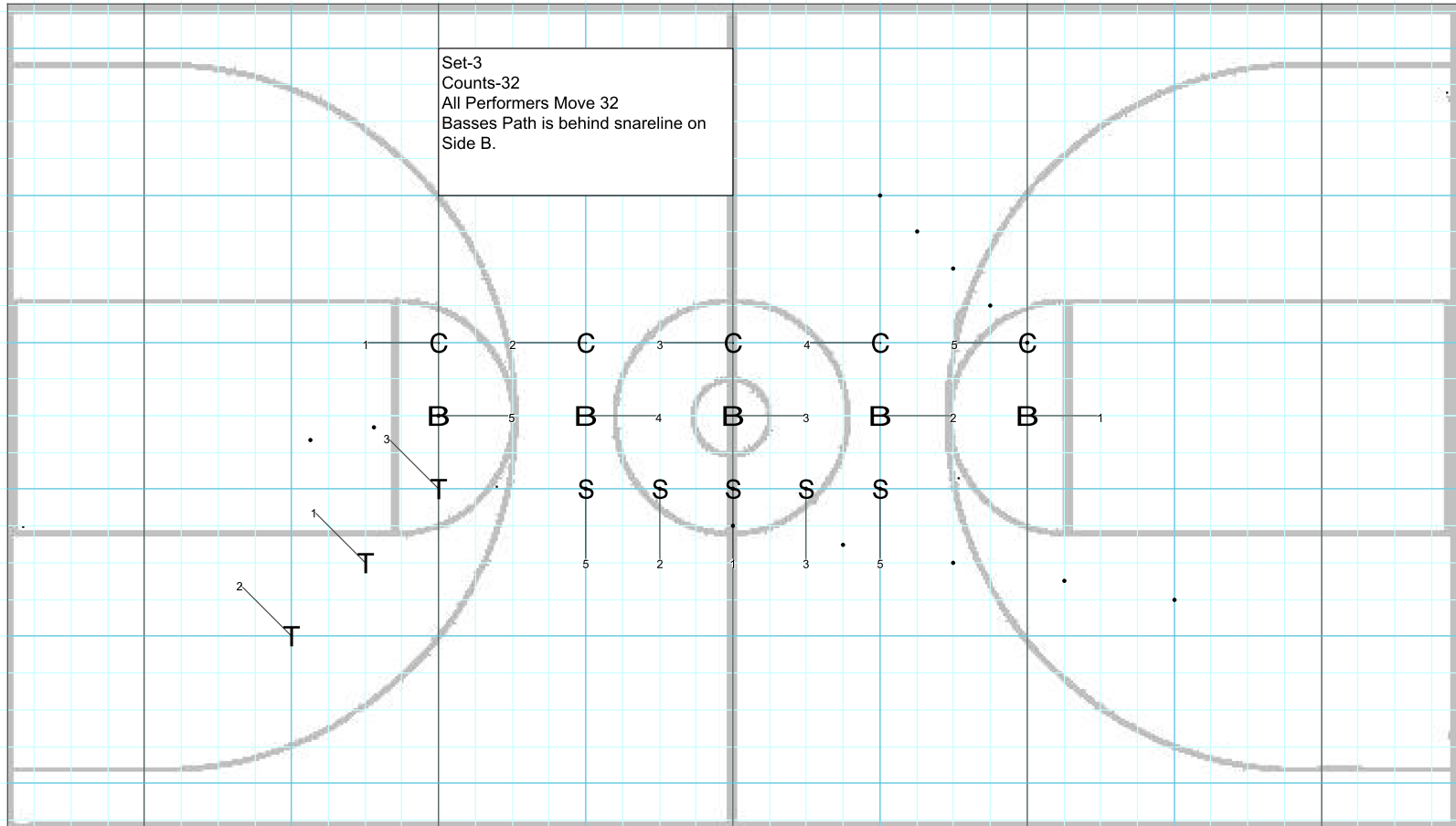

2-333333

10

5

0

5

10

12-333333

Director Viewpoint

2-333333

10

5

0

5

10

12-333333

Set-4
 Counts 12
 All Performers Move 12
 Tenors Hold 12
 Snares Face back field on Move

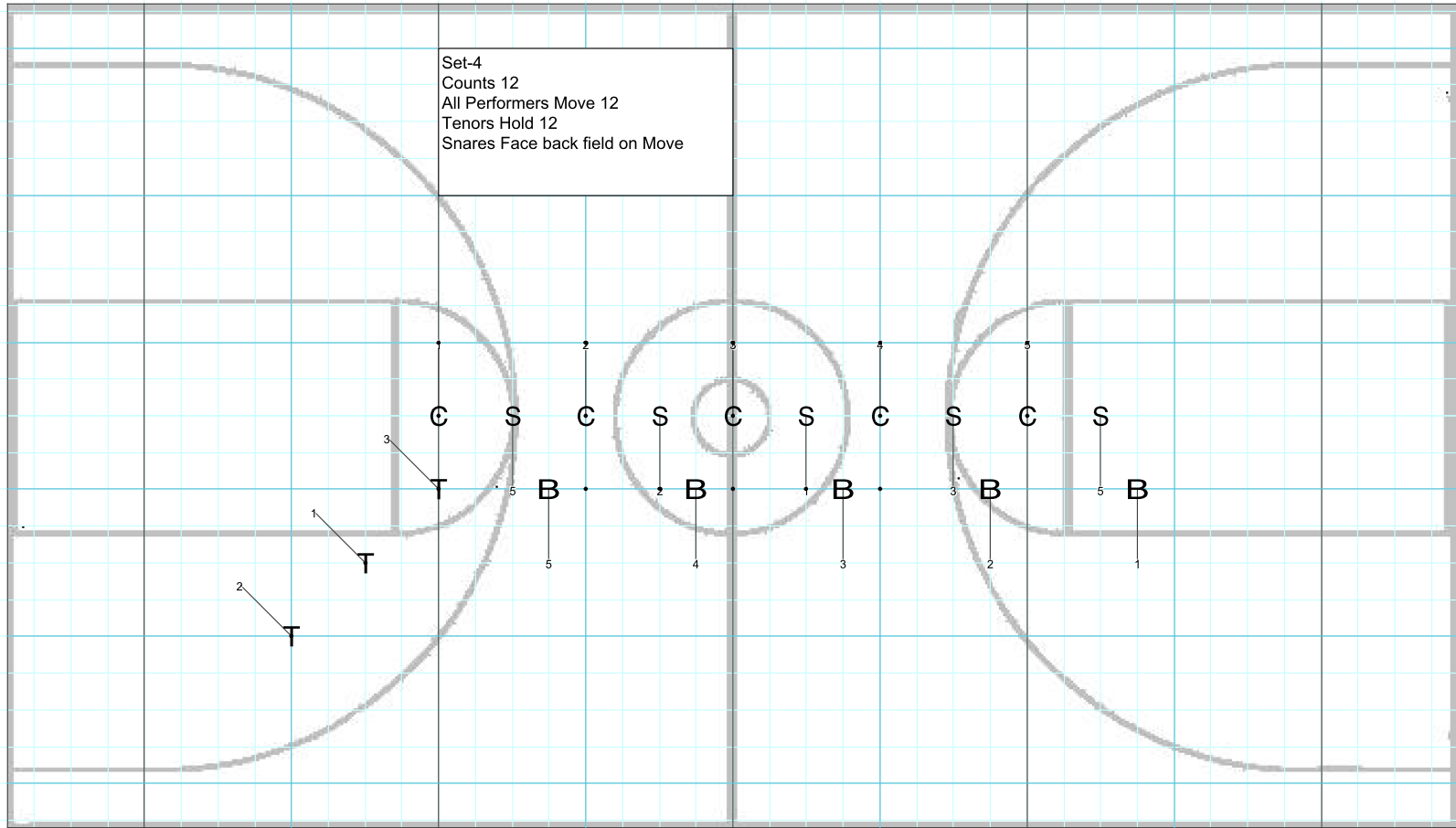

2-333333

10

5

0

5

10

12-333333

Director Viewpoint

2-333333

10

5

0

5

10

12-333333

Set 5
Counts 20
All Performers Move 8 Hold 12
Snare face frontfield on touch and go

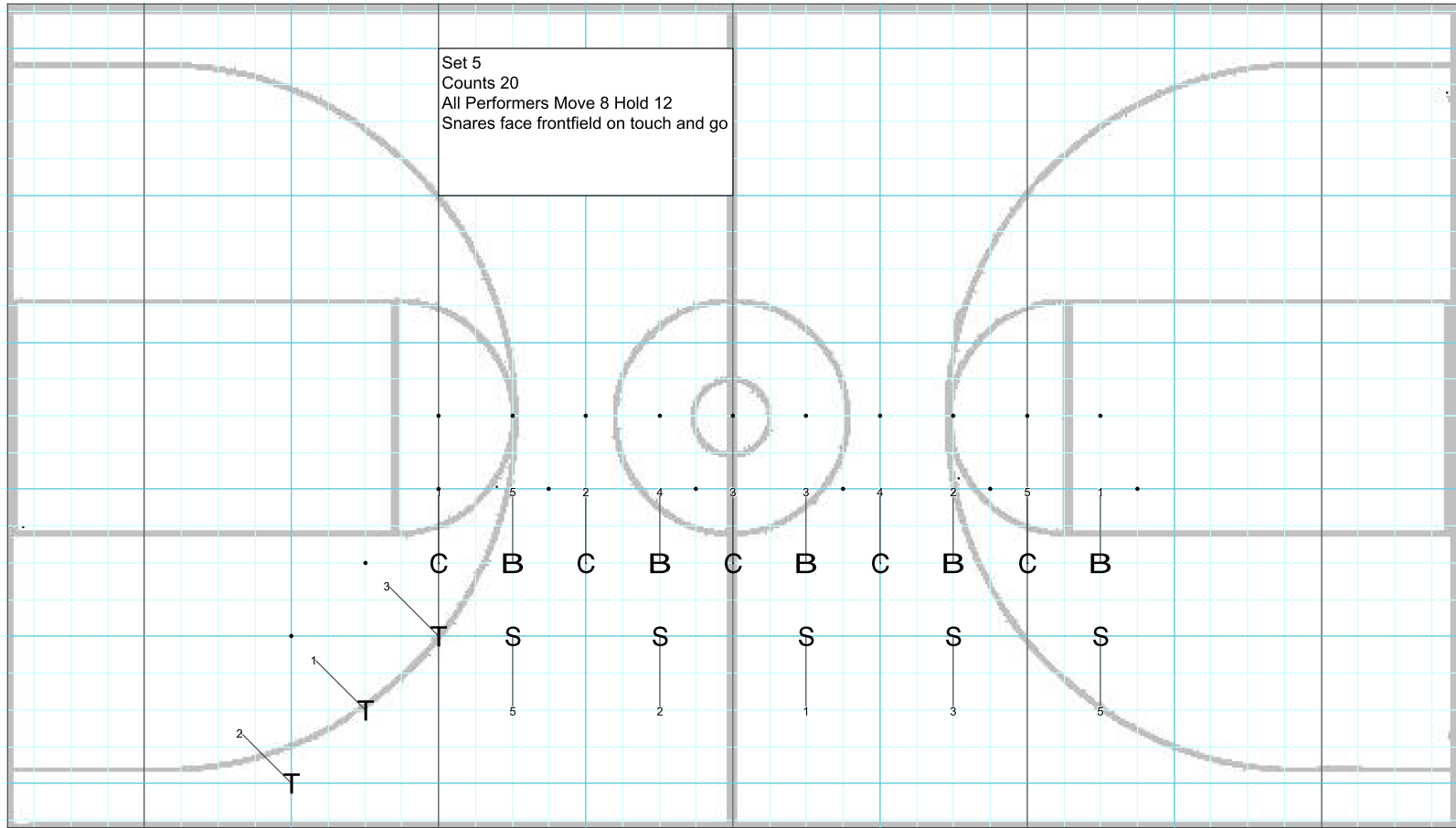

2-333333

10

5

0

5

10

12-333333

Director Viewpoint

2-333333

10

5

0

5

10

12-333333

Set-6
Counts-32
All Performers Move 16 Hold 16

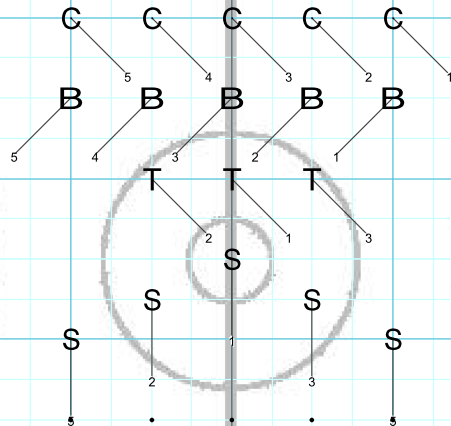

2-333333

10

5

0

5

10

12-333333

Director Viewpoint